

# TDC1 Series

## Low-Power Non-Intrusive PIR Traffic Detectors for Single Lane Traffic Data Acquisition



The TDC1 Series are advanced traffic detectors using Passive Infrared technology. Comprehensive traffic data including individual vehicle class, speed, length, occupancy time and time gap are provided via RS 485 databus.

### Typical Applications

ADEC TDC1 Series detectors are specifically designed for a variety of **Traffic Data Collection** and traffic control applications where low power consumption is required:

- Vehicle counting (volume)
- Individual vehicle speed
- Vehicle classification
- Presence detection

### Working principle

TDC1 traffic detectors employ multiple PIR detection zones. A combination of static and dynamic detection channels form a total of five detection zones. The thermal radiation contrast of a vehicle moving into or through the detection zones against the background radiation of the road surface correlates to the passage or presence of a vehicle. The sophisticated signal processing transforms the sensors analog data into digital information for each event without the need for external computing equipment.

### Mounting

Recommended mounting points are gantries, overpasses or bridges or alternatively on a pole at the roadside. Clearly superior performance and reliability are a result of:

- Multi-channel PIR detection
- Full temperature compensation across entire temperature range
- Sophisticated algorithms eliminating impact of environmental changes

### Features

- **Ultra low power consumption**  
≤ 60 mW, ideal for solar powered installations
- **Multi channel PIR detection**  
Total of five detection zones
- **Vehicle classification by length**  
3 standard classes, up to 5 vehicle classes possible (depending on customer length threshold setting)
- **Auto calibration**  
Auto calibration using mounting height and distance to the centre of the observed lane via dedicated commissioning software
- **Wide mounting height range**  
Mounting height between 5.5 m and 18 m (max. offset 45° from detector's mounting location to the centre of the observed lane), *Application-dependent limitations apply.*
- **Detection of standing vehicles**
- **Detection of wrong-way drivers**
- **Wide operating temperature range (−40 to +70°C (−40 to +158°F))**  
Optimal performance in all weather and climate conditions
- **Remote configuration and setup**  
With dedicated commissioning and installation software

### Field of view

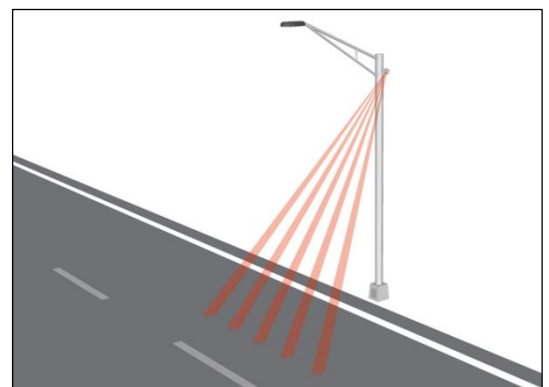

## Technical Specifications

Electrical	
Supply Voltage	5.5 ... 30 V DC
Power Consumption	typ. 10 mA @ 6 V DC
Output (Data Transfer)	RS 485 (other options on request)
Turn-on Time	typ. 20 s from power on
Mechanical	
Dimensions	see drawing
Case Material	Polycarbonate, dark grey
Weather Protection Enclosure	stainless steel V4A
Weight	app. 960 g incl. bracket
Detection	
PIR Sensors	5 channel PIR
PIR Spectral Response	6.5 ... 14 $\mu$ m
Accuracy	
Counting	typ. $\pm$ 3%
Speed	typ. $\pm$ 5% (> 100 km/h) typ. $\pm$ 5km/h ( $\leq$ 100 km/h)
Classification	3 standard classes, each 95% The specifications refer to free traffic flow, detector operated in recommended setup.
Environmental	
Operating Temperature	-40°C to +70°C (-40 to +158°F)
Humidity	95 % RH max.
Sealing	IP 64 splash proof

## Mechanical Dimensions

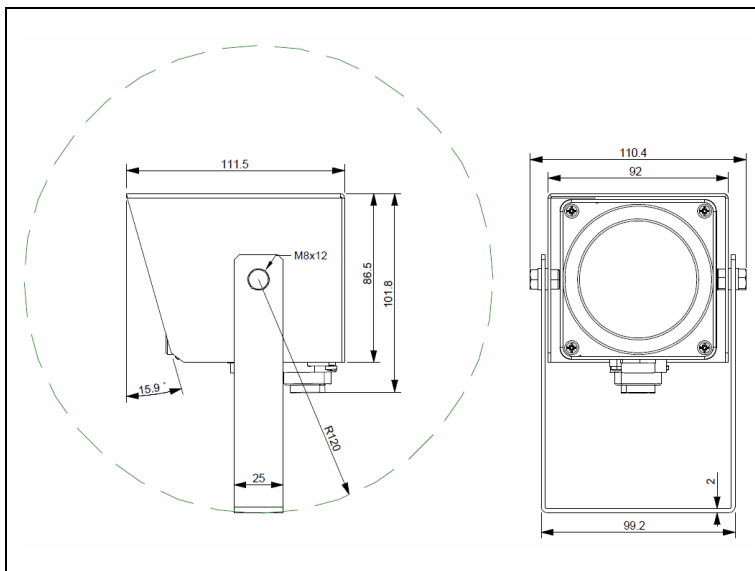

### Important:

Data is based on samples and believed to be representative.  
Design and specification changes reserved without prior notice.  
For more specific information on the products, their installation and application please refer to the installation manual or contact the manufacturer.

## Accessories (Sold Separately)

### Interface RS 485 & Software

For the communication between detectors and a PC during commissioning and maintenance an interface module in combination with the dedicated software is necessary. The interface module and software have to be ordered separately.



USB IF 485: **Order Number 12501**

### Mounting Accessories

A bracket for mounting the detector on a round pole is available as separate accessory (not included in standard delivery).

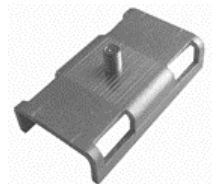

TDC-PMA: **Order Number 14101**

### Alignment Tool

ADEC offers a mechanical alignment tool for quick and accurate installation. The tool can be easily put on top of the device and allows the installer to align the detector using the integrated level and sight.



TDC-AH: **Order Number 12601**

### Alignment Tool with Camera and Monitor

Designed for installations where the normal alignment help cannot be used, this alignment tool features a built-in camera and a small, battery-powered monitor.



TDC-AH-E: **Order Number 12602**

### BS2 - Base Station 2

Fully self-contained station integrating GSM modem, batteries and PV panel with charger. ADEC cloud-integrated setup using DET-Soft commissioning software



BS2-TS2: **Order Number 11308**

## Model Overview

- **TDC1-PIR** (Order Number: 10000)